

A Study on the Improvement of Heat Transfer Performance in Low Temperature Closed Thermosyphon

Kyu-II Han*, Seok-Su Yee, Sung-Hyun Park, Suk-Ho Lee

*School of Mechanical Engineering, Pukyong National University,
Busan 608-739, Korea*

Dong-Hyun Cho

*Department of Mechanical Design Engineering, Daejin University,
Seoul 487-711, Korea*

The study focuses on the heat transfer performance of two-phase closed thermosyphons with plain copper tube and tubes having 50, 60, 70, 80, 90 internal grooves. Three different working fluids (distilled water, methanol, ethanol) are used with various volumetric liquid fill charge ratio from 10 to 40%. Additional experimental parameters such as operating temperature and inclination angle of zero to 90 degrees are used for the comparison of heat transfer performance of the thermosyphon. Condensation and boiling heat transfer coefficients, heat flux are obtained using experimental data for each case of specific parameter. The experimental results are assessed and compared with existing correlations. The results show that working fluids, liquid fill charge ratio, number of grooves and inclination angle are very important factors for the operation of thermosyphons. The relatively high rate of heat transfer is achieved when the thermosyphon with internal grooves is used compared to that with plain tube. The optimum liquid fill charge ratio for the best heat transfer performance lies between 25% and 30%. The range of the optimum inclination angle for this study is 20°~30° from the horizontal position.

Key Words : Boiling, Condensation, Working Fluid, Latent Heat, Inclination Angle, Liquid Fill Charge Ratio, Heat Transfer Coefficient, Thermosyphon

Nomenclature

b : Distance between grooves (m)
 c_p : Specific heat (J/kg·K)
 D : Diameter (m)
 g : Gravitational acceleration (m/s²)
 h : Heat transfer coefficient (W/m²·K)
 h_{fg} : Latent heat of vaporization (J/kg)
 K : Thermal conductivity (W/m²·K)
 L : Length (m)
 P : Pressure (Pa)
 q : Heat flux (W/m²)
 R : Radius (m)

T : Temperature (K)

Greek Letters

ρ : Density (kg/m³)
 μ : Dynamic viscosity (N·s/m²)
 θ : Inclination angle from the Horizontal (°)
 ϕ : Liquid fill charge ratio (%)

Subscripts

atm : Atmosphere
 avg : Average
 c : Condensation section
 e : Evaporation section
 l : Liquid
 Nu : Nusselt
 sat : Saturated
 v : Vapor
 w : Wall
 Y : Yiwei

* Corresponding Author.

E-mail : kihan@pknu.ac.kr

TEL : +82-51-620-1581; **FAX :** +82-51-620-1574

School of Mechanical Engineering, Pukyong National University, Busan 608-739, Korea. (Manuscript Received April 2, 2001; Revised June 10, 2002)

1. Introduction

High heat transfer rates are involved in boiling and condensation. There are two types of closed systems which are two-phase close thermosyphon and heat pipe using evaporation and condensation process. Two-phase closed thermosyphon is sometimes called a wickless heat pipe. Working fluid is returned by capillary force in the heat pipe, while circulation in the thermosyphon is achieved by gravitational or centrifugal force. Two-phase closed thermosyphon has many advantages such as a large amount of heat transfer capability using latent heat, uniform temperature distribution by vapor flow's heat diffusion, light and simple structure, fast heat response characteristics.

Many researches on thermosyphons have been performed due to these advantages since the principle of thermosyphon was suggested first by Gaugler (1942).

Such researches focused on pool boiling in evaporator section, liquid film boiling and working principle of thermosyphon based on its flow pattern, the improvement and the estimation of heat transfer coefficient. Imura et al. (1977) reported that the critical heat flow of thermosyphon is 1.2~1.5 times higher than that of heat pipe. Research on the heat transfer in the thermosyphon was also performed by Cohen and Bayley (1955) and followed by Larkin (1971), Lee and Mital (1972), Stret'sov (1975), Andros (1980). They agree that heat transfer performance of two-phase closed thermosyphon is affected by working fluid, liquid fill charge ratio, inclination angle, internal diameter and length of thermosyphon, heat flux, working fluid vapor pressure. Park (1992), Sterling and Tichacek (1961) carried out the researches on the effect of the types of working fluid and Chen (1987), Botemps et al. (1987), Fledman and Srinivasan (1984), Imura (1977), Cohen and Bayley (1955), Lee and Mital (1972) performed the research on the effect of liquid fill charge ratio. Tu et al. (1984), Hahne and Gross (1981), Negishi and Sawards (1983), Cho and Kwon (1997), Qi and

Lang (1999) have reported the effect of inclination angle. Tube diameter effect on the heat transfer coefficient was performed by Lee and Clements (1981). But plain tube was used in most of those studies and only a few research was performed using internal grooved tube. Heat pipe with internal triangular shaped groove was analyzed by Peterson and Ma (1996). A large effect for improving heat transfer rate is expected in thermosyphon when internal grooved tube is used. Hong et al. (1998) carried out the research on the thermosyphon with internal groove.

In this paper, experimental studies on the vertical and the inclined thermosyphon with internal grooves have been carried out. Especially the effects of number of grooves, inclination angle, liquid fill charge ratio, types of working fluid on the heat transfer rate were investigated and analyzed.

2. Experimental Apparatus and Method

Figure 1 shows the schematic diagram of the experimental apparatus. It consists of five parts such as test section, cooling water circulation line, heating water circulation line, high vacuum system, temperature measurement and recording system. The geometric specification of the plain and grooved thermosyphon is shown in Table 1. And 20 times enlarged cross-sectional view of internal groove is shown in Fig. 2. Test section of the thermosyphon is illustrated in Fig. 3.

The total length of the thermosyphon is 1200 mm. It consists of evaporation and conden-

Table 1 Geometric specifications of grooved thermosyphon

No	Tube		Groove				
	Do (mm)	Di (mm)	Number (No.)	Depth (mm)	Angle (°)	b (mm)	b/Di
1	15.85	14.35	50	0.29	42	0.60	0.0418
2	15.85	14.35	60	0.29	42	0.45	0.0314
3	15.85	14.35	70	0.29	42	0.34	0.0237
4	15.85	14.35	80	0.29	42	0.26	0.0181
5	15.85	14.35	90	0.29	42	0.20	0.0139

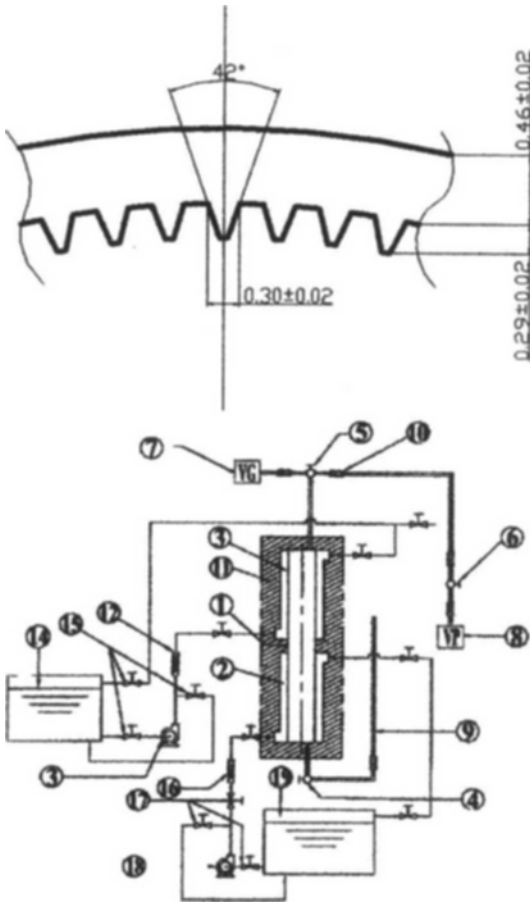

1. Test Tube 2. Heating Water Chamber 3. Cooling Water Chamber 4. Vacuum Valve 5. Vacuum Valve 6. Vacuum Rubber Hose 7. Vacuum Gauge 8. Vacuum Pump 9. Measuring Device for Liquid 10. Vacuum Rubber Hose 11. Insulation 12. Coolant Flow Meter 13. Coolant Pump 14. Coolant Constant Temperature Bath 15. Coolant Control Valve 16. Heating Water Flow Meter 17. Heating Water Control Valve 18. Heating Water Pump 19. Heating Water Constant Temperature Bath

Fig. 1 Schematic diagram of experimental apparatus

sation section with 550 mm in length respectively and adiabatic section with 100 mm in length. The test tube has a 14.3 mm inner diameter and a 15.8 mm outer diameter.

Two 550 mm long water jackets are set on the test tube as mentioned above. One is used as a heating jacket for an evaporator and the other is used as a cooling jacket for a condenser. An inlet small tube for heating or cooling water flow into

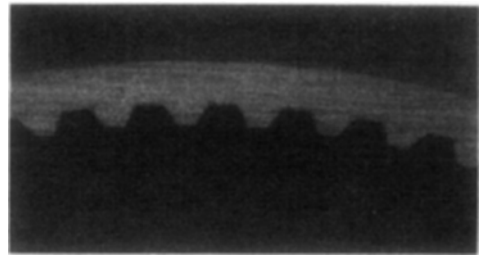

Fig. 2 Enlarged cross-sectional view of internal grooves (60 grooves)

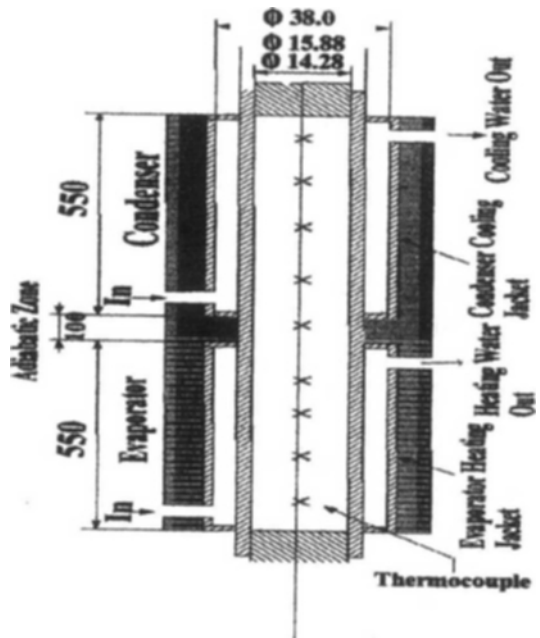

Fig. 3 Cross-sectional view of the experimental two-phase closed thermosyphon

each jacket is directed at a tangent to the inside surface of the jacket.

The thermosyphon can be positioned with any inclination angle from 0° to 90° with respect to the horizontal position. Nine thermocouples are soldered on the outside surface of the tube along its length to measure surface temperatures. Another nine thermocouples are inserted into the inside of thermosyphon to measure inside vapor temperatures. Four more Pt. 100 temperature sensors are placed at the inlets and the outlets of two water jackets. The temperature outputs are recorded on a data logger and it is connected to

personal computer to analyze recorded data.

A rotary vacuum pump and a diffusion pump with a rating of 10^{-6} Torr are used to remove air and other non-condensable gases. Distilled water, methanol and ethanol are chosen as working fluids, since these are compatible with copper and safe materials to work with. Hashimoto et al. (1999) reported that the considerable decrease of condensation heat transfer might be caused by the non-condensable gas.

In order to eliminate the non-condensable gas, a little more than exact quantity of working fluid is injected into the tube after evacuating air.

After injecting the working fluid, heating and cooling water flow into the evaporator and the condenser jackets, respectively. A small amount of non-condensable gas was collected at the end of the condenser after a few minutes of operation. This gas is removed again by vacuum pump for perfect operation of thermosyphon. All of the residual working fluid in the test tube was collected after each run of experiment and its volume was measured to compare the exact quantity of working fluid. Only a data with no volumetric difference was taken. The experimental conditions

are set as follows. The heating and cooling water temperature are varied. Two constant water temperature baths support hot or cool water continuously within ± 0.1 °C difference for each setting temperature. The temperature distribution, heat flux, heat transfer coefficients (condensation, boiling) are obtained with respect to inclination angle, liquid fill charge ratio, distance between grooves, temperature changes of heating water or cooling water and working fluids. An uncertainty analysis along the lines suggested by Kline and McClintock (1953) showed that the uncertainty due to measurement errors in the determination of q_e and q_c was about 3.9 and 5.0 percent, respectively. An uncertainty for the value of h_e at a ΔT of 4.6 K is about 6.9 percent and that for the value of h_c at a ΔT of 3.0 K is about 8.8 percent.

3. Results and Discussion

3.1 Temperature distribution of outside wall of thermosyphon

Temperature distributions of the heated wall, adiabatic section and cooled wall on the thermosyphon with plain tube are shown in Fig. 4

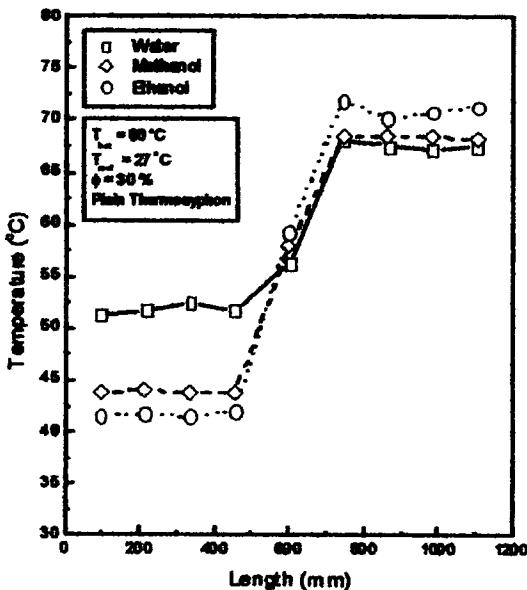

Fig. 4 Temperature distribution along the length of plain thermosyphon

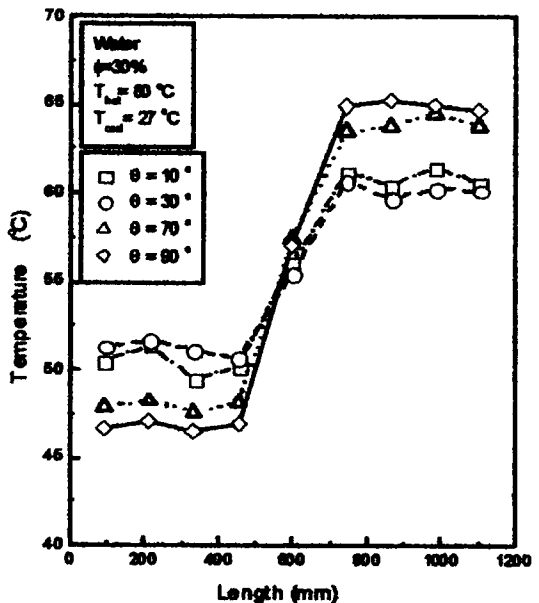

Fig. 5 Temperature distribution along the length of plain thermosyphon

and Fig. 5. Heating water temperature is 80 °C and liquid fill charge ratio is 30% in both Figures. The liquid fill charge ratio means the ratio of the volume of working fluid charged in the test tube to the total internal volume of the test tube. The flow rates of heating and cooling water are fixed as 0.4 m³/h, respectively. The working fluids used in Fig. 4 are water, methanol and ethanol. The temperature difference between the heated and cooled wall using water as a working fluid is closer to adiabatic temperature compared to those when methanol and ethanol are used as a working fluid. This means that using the working fluid with high latent heat such as water is good for obtaining high heat transfer rate.

Figure 5 shows the temperature distributions along the length of plain thermosyphon as a variation of inclination angle. Temperature distribution on heated wall looks relatively constant but that on cooled wall is a little scattered. The condensate film seems to flow downward irregularly as rivulet on the internal surface of condensing section.

Lower heated wall temperature and higher cooled wall temperature mean high heat transfer performance of thermosyphon. When thermosyphon is inclined to about 30°, the highest heat transfer performance is obtained.

3.2 Heat flux and heat transfer coefficient

Relation between boiling heat flux and the difference of wall temperature and saturated vapor temperature is shown in Fig. 6. Heat flux increases as the temperature difference increases and data of grooved tube locates higher than data of plain tube.

The slope line on the data of grooved tube which represents boiling heat transfer coefficient is larger than the slope line on the data of plain tube. Nominal internal diameter which has the same value as that of the plain tube was used for the calculation of internal surface area for the grooved tube. This means that heat transfer coefficient for the case of the grooved tubes is considered as effective heat transfer coefficient. The heat flux enhancement effect due to the increase of internal surface area is already inclu-

ded in the increase of heat transfer coefficient.

Figure 7 shows condensation heat transfer coefficient for plain and 60 grooved thermosy-

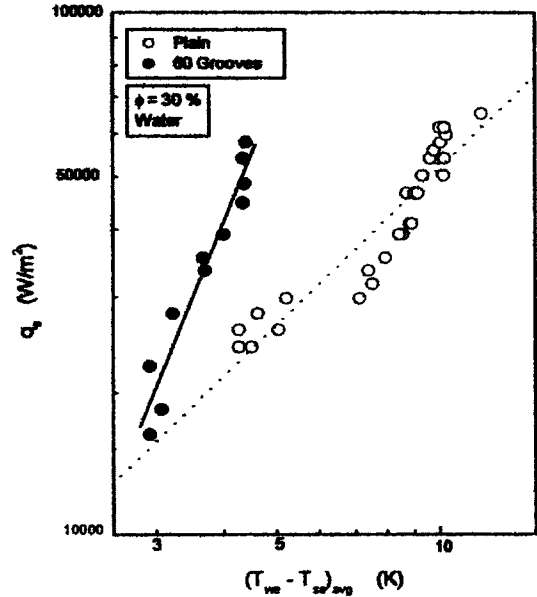

Fig. 6 Measured average heat flux vs. temperature excess (The solid and dotted line were determined by a least squares method.)

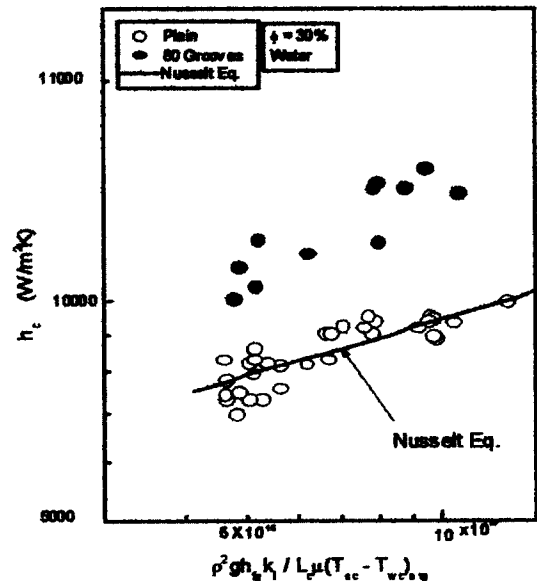

Fig. 7 Comparison of condensation heat transfer coefficient between plain and grooved thermosyphon

phon. 30% of liquid fill charge ratio and water as a working fluid are used. Plain tubes data is compared with Nusselt's condensation theory (1916) and the data matches well with his theory. Condensation heat transfer coefficient for 60 grooves is higher than that of plain tube in all

range of experimental data. The maximum enhancement of coefficient is about 2.5.

Boiling heat transfer coefficients of both tubes are shown in Fig. 8 and Fig. 9.

All the data of plain thermosyphon is correlated well with Imura's empirical relation (1977). Imura's correlation is represented below.

$$h_e = 0.32Z \left(\frac{P_{sat}}{P_{atm}} \right)^{0.3}$$

where

$$Z = \frac{\rho_l^{0.65} k_l^{0.3} C_{pl}^{0.7} g^{0.2} q_e^{0.4}}{\rho_v^{0.25} h_{fg}^{0.4} \mu_l^{0.1}} \quad (1)$$

Experimental data is obtained with changes of heat input of evaporation section of thermosyphon. Boiling heat transfer coefficient increases as an increase of heat flux. Sixty groove tube shows higher value than plain tube, which is a similar result as the case of condensation. Coefficient of grooved tube is 1.5~2 times higher in methanol and 1.3~1.5 times higher in ethanol compared to that of plain tube.

3.3 Effect of inclination angle and liquid fill charge ratio

Figure 10 represents the effect of inclination angle on the condensation heat transfer coefficient. Experimental data is compared with Nusselt's (1916) and Yiwei's empirical relations (1989) shown below.

$$h_{Nu} = 0.943 \left[\frac{\rho_l^2 g h_{fg} k_l^3 \sin \theta}{L_c \mu_l (T_{sc} - T_{wc})_{avg}} \right]^{1/4} \quad (2)$$

$$\frac{h_{\tau}}{h_{Nu}} = P_{sat}^{0.37} \left(\frac{L_c}{R} \right)^{\frac{\cos \theta}{4}} [0.41 - 0.72 \phi + (-62.7 \phi^2 + 14.5 \phi + 7.1) \theta / 1000] \quad (3)$$

Plain tube data is correlated well with Yiwei's empirical Eq. (3). As inclination angle decreases from vertical to horizon position, gravitational force and frictional force are both decreased at the same time. However, condensation heat transfer coefficient is proportional to gravitational force while it is inversely proportional to frictional force. And optimum inclination angle exists between 10° and 90°. The maximum value of condensation heat transfer coefficient for this study exists at the angle of 20°~30°. The enhancement of coefficient results from the effects of inclination angle and internal groove of the tube.

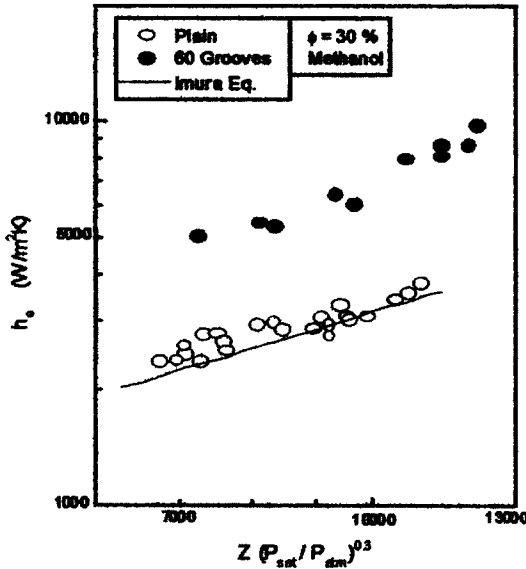

Fig. 8 Comparison of the experimental data with correlation by Imura

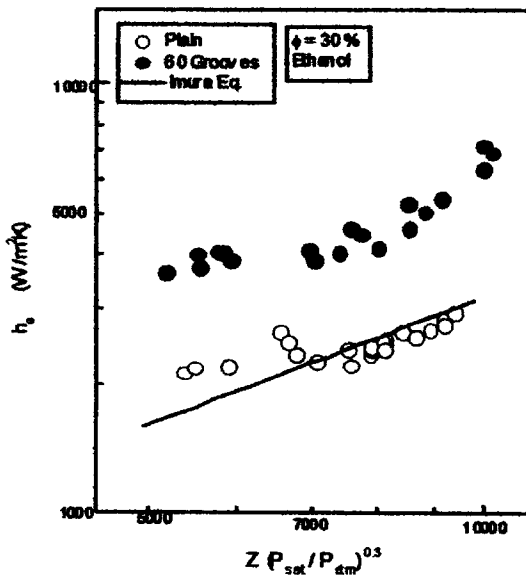

Fig. 9 Comparison of the experimental data with correlation by Imura

The effect of liquid fill charge ratio on the condensation heat flux is shown in Fig. 11. Condensation heat transfer performance is analyzed by 5 different liquid fill charge ratios such as 10, 20, 25, 30, 40%. Thermosyphon is inclined from

10° to 90° for each case. 25% of fill charge ratio shows the highest heat flux and 10% is the lowest. When liquid fill charge ratio is optimum, the saturated liquid flows down along the inside tube wall as a film and the saturated vapor flows up in the core of the tube. When the liquid fill charge ratio is too large, the heat transfer mechanism in the condenser section changes from film condensation to a two-phase mixture convection which causes the decrease of thermosyphon performance. If the liquid fill charge ratio is too low, there appears a dry-spot on the internal wall due to the breakdown of the film which also causes low performance of thermosyphon. As shown in the Fig. 11, heat flux increases from 10% up to 25% and after that it decreases until the ratio reaches to 40%.

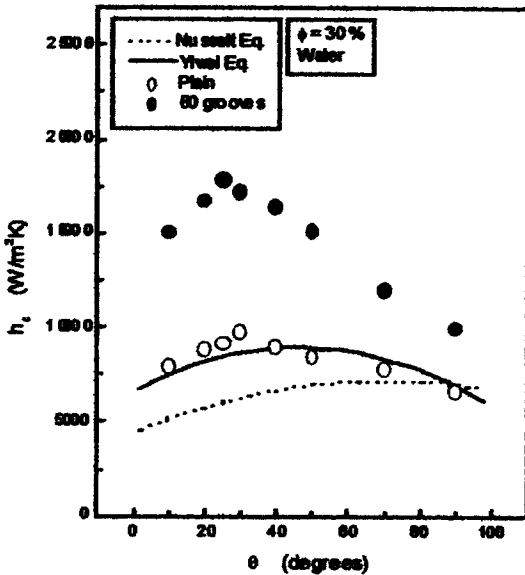

Fig. 10 Effect of inclination angle on the condensing heat transfer coefficient for the plain and the grooved thermosyphon

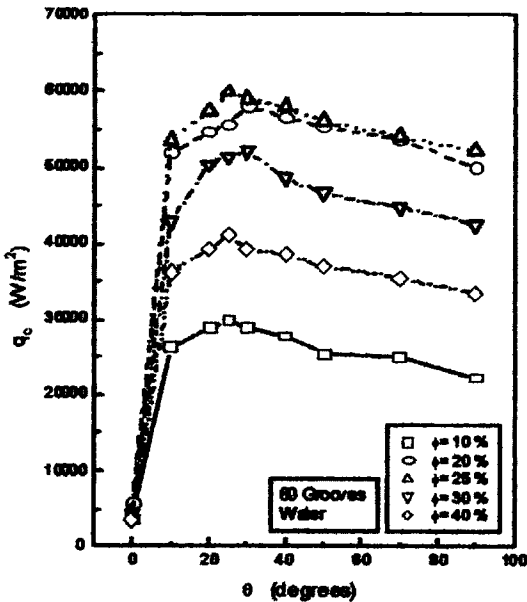

Fig. 11 Plot of heat flux against inclination angle

3.4 Effect of distance between grooves

Figures 12 and 13 show the condensation heat flux against the vapor-to-wall temperature difference. The number of grooves varies from 50 to 90. The results of all of the grooved tubes locate higher than that of plain tube. The high-

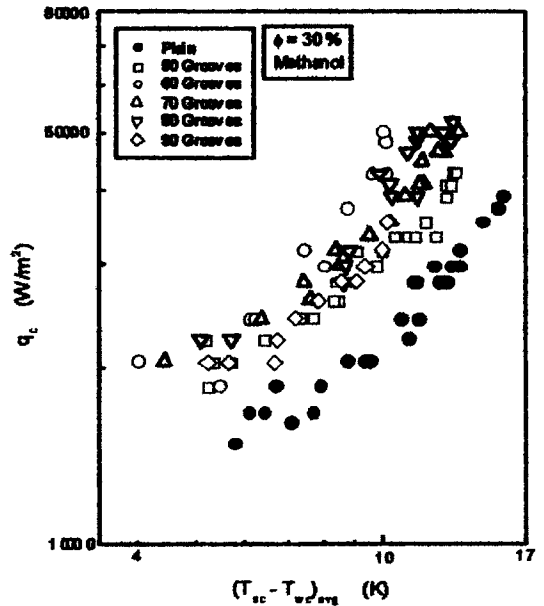

Fig. 12 Measured average heat flux vs. vapor-to-wall temperature difference of the condenser zone

hest is sixty groove and the lowest is plain and the rest of it is positioned in between. Heat transfer surface increase by increased groove density results in heat transfer enhancement. How-

ever, the increase of capillary force interrupts the saturated liquid to flow downward opposed to a gravitational force. This means that the increased flow resistance caused by narrow groove width caused the decrease of heat transfer rate. There-

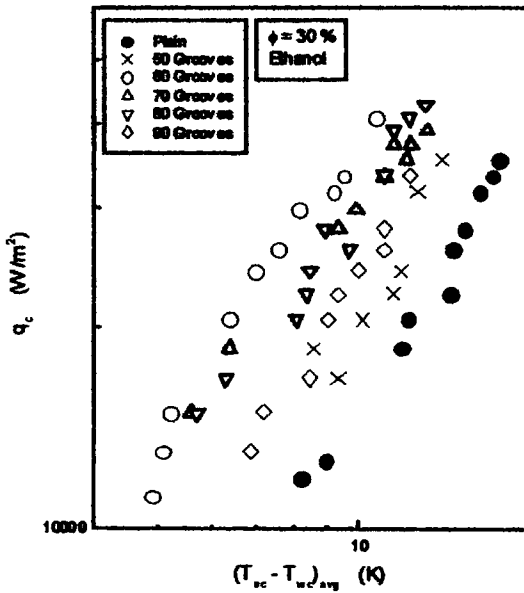

Fig. 13 Measured average heat flux vs. vapor-to-wall temperature difference of the condenser zone

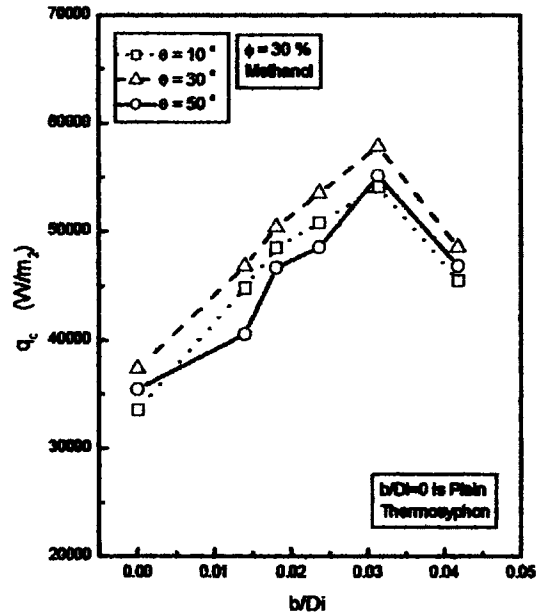

Fig. 15 Effects of the distance between grooves on the measured average heat flux

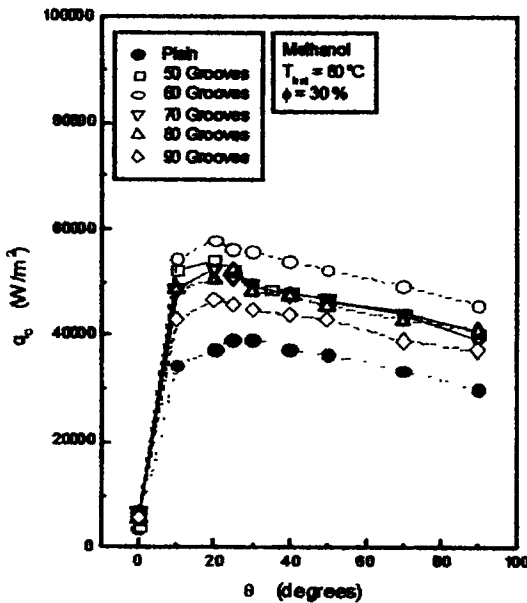

Fig. 14 Plot of heat flux against inclination angle

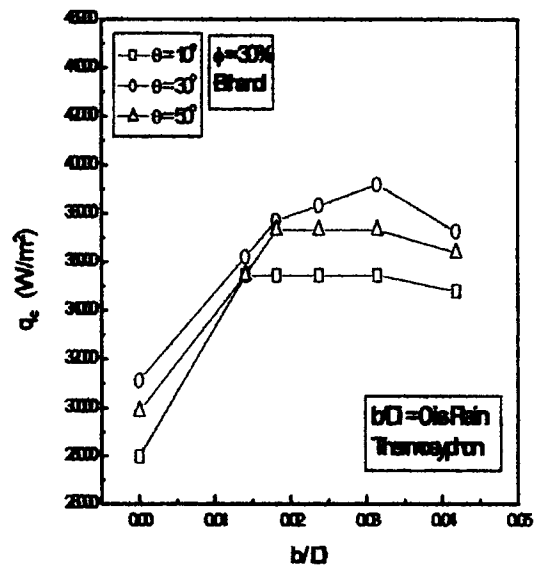

Fig. 16 Effects of the distance between grooves on the measured average heat flux

fore, the optimum distance between grooves must be decided by considering three effects of surface area, capillary and gravitational force at the same time.

Figure 14 through Fig. 16 show the heat flux vs. number of groove. As shown in the Figures, the heat transfer performance has the highest value at the inclination angle of 20° ~ 30° and 60 grooves ($b/D_i=0.0314$), respectively.

4. Conclusions

In this study, plain tube and the tubes having 50, 60, 70, 80, 90 internal grooves are investigated for the comparison of heat transfer performance of low temperature closed thermosyphon. As the experimental parameters, working fluids (distilled water, methanol, ethanol), liquid fill charge ratio (10% to 40%), and inclined angle (0° to 90°) are used.

The conclusions of this study can be summarized as follows :

(1) Both of boiling and condensation heat flux increases as the difference of internal wall temperature and saturated vapor or liquid temperature increases.

(2) The inclination angle of a thermosyphon has a notable influence on the condensation heat transfer coefficient and the optimum inclination angle lies between 20° and 30° .

(3) All the thermosyphon with 25% of liquid fill charge ratio showed the highest heat flux.

The best condensation heat transfer performance was obtained for 60 grooves, and the maximum value of this case is 2.5 times higher than that of the plain tube.

Acknowledgment

This work was supported by the research fund of Pukyong National University in 2000.

References

Andros, F. E., 1980, "Heat Transfer Characteristics of the Two-Phase Closed Thermosyphon (Wickless Heat Pipe) Including Direct Flow

Observation," Ph. D. Thesis, Arizona State University.

Botemps, A., Goubier, C., Marquet, C., Solecki, J. C. and Nardi, C., 1987, "Performance Limits of a Toluene Loaded Closed Two-Phase Thermosyphon," *6th IHPC*, Grenoble, pp. 634~644.

Chen, M. M., 1987, "Heat Transfer Performance of Two-Phase Closed Thermosyphons with Different Lengths," *6th IHPC*, Grenoble, pp. 647~651.

Cho, D. and Kwon, H., 1997, "A Experimental Study on the Heat Transfer Performance inside inclined Thermosyphon for the Effect of the Ratio of Reynolds Number of Cooling to Hot Water," *Proc. KSME Spring Conf.*, pp. 405~410.

Clement, B. and Lee, Y., 1981, "Additional Parameters in Two-Phase Closed Thermosyphon: Effects of Tube Diameter and Wall Thickness," *Int. J. of Heat and Mass Transfer*, Vol. 24, No. 9, pp. 1554~1555.

Cohen, H., Bayley, F. J., 1955, "Heat Transfer Problem of Liquid Cooled Gas Turbine Blades," *Proc. Inst. Mech. Eng.*, 169-20, pp. 1063~1080.

Fledman, K. T., Srinivasan, Jr. and R., 1984, "Investigation of Heat Transfer Limits in Two-Phase Closed Thermosyphon," *5th IHPC, Tsukuba*, pp. 30~35.

Gaugler, R. S., 1944, Heat Transfer Device, US Patent No. 2350348, US Patent Application. Dec. 21, 1942.

Hahne, E. and Gross, U., 1981, "The Influence of the Inclination Angle on the Performance of a Closed Two-Phase Thermosyphon," *4th IHPC*, London, pp. 125~135.

Hashimoto, H., Kaminaga, F. and Matsumura, K., 1999, "Study on Condensation Heat Transfer Characteristics in a Thermosyphon with Non-Condensable Gas Effect," *11th IHPC*, Vol. 1, pp. 121~126.

Hong, J., Boo, J. and Jung, Y., 1998, "Experiments on the Thermal Performance of a Thermosyphon in Inner Grooved Copper Tube," *Proc. SAREK Summer Conf.*, pp. 313~317.

Imura, H., Kusuda, H., Ogata, J. I., Miyaz, T. and Sakamoto, N., 1977, "Heat Transfer in Two-Phase Closed-Type Thermosyphons," *Trans. of*

Japan Soc. of Mech. Engrs., pp. 485~493.

Kline, S. J. and McClintock, F. A., 1953, "Describing Uncertainties in Single-Sample Experiments," *Mechanical Engineering*, Vol. 75, pp. 3~8.

Larkin, B. S., 1971, "A Experimental Study of the Two Phase Thermosyphon Tube," *Trans. Canda. Soc. Mech. Engrg.*, 14-B6, pp. 1~8.

Lee, Y. and Mital, U., 1972, "A Two-Phase Closed Thermosyphon," *Int. J. of Heat and Mass Transfer*, 15-9, pp. 1695~1707.

Negishi, K. and Sawards, T., 1983, "Heat Transfer Performance of an Inclined Two-Phase Closed Thermosyphon," *Int. J. of Heat and Mass Transfer*, Vol. 26, No. 8, pp. 1207~1213.

Nusselt, W., 1916, Die Oberflächenkondensation des Wasserdampfes, *Z. Ver. Deut. Ing.*, 60.

Park, R. J., 1992, "Two-Phase Closed Thermosyphon with Two-Fluid Mixtures," M. S. Thesis, Department of Mechanical Engineering, University of Ottawa, Ottawa, Ontario, Canada.

Peterson, G. P. and Ma, H. B., 1996, "Experimental Investigation of the Maximum Heat Transport in Triangular Groove," *ASME J. of Heat*

Transfer, Vol. 35, No. 3, pp. 740~746.

Qi, W. and Lang, Y., 1999, "Heat Transfer Characteristics of a Closed Two-Phase Thermosyphon Working with a Binary Mixture at Different Incline Angles," 11th IHPC, Vol. 1, pp. 110~115.

Sterling, C. O. and Tichacek, L. J., 1961, "Heat Transfer Coefficients for Boiling Mixtures," *Chem. Engrg Sci.*, 16, pp. 297~337.

Stre'tsov, A. I., 1975, "Theoretical and Experimental Investigation of Optimum Filling for Heat Pipes," *Heat Transfer, Soviet Research*, Vol. 7, No. 1, pp. 23~27.

Tu, C., Xie, G., Hu, C., Gao, Z. and Hong, R., 1984, "The Two Phase Closed Thermosyphon: an Experimental Study with Flow Pattern and Optimum Fill Charge," *China-U. S. Seminar on Two-flows and Heat Transfer, Sian*, pp. 395~405.

Yiwei, M., Wang, J. C. Y., Jifu, L. and Yi, F., 1989, "Theoretical and Experimental Studies on Condensation Heat Transfer inside Vertical and Inclined Thermosyphons," *National Heat Transfer Conference HTD-vol. 108*, pp. 111~116.